

Reverse SMA STRAIGHT PLUG REVERSE POLARITY

32RS147-306F3

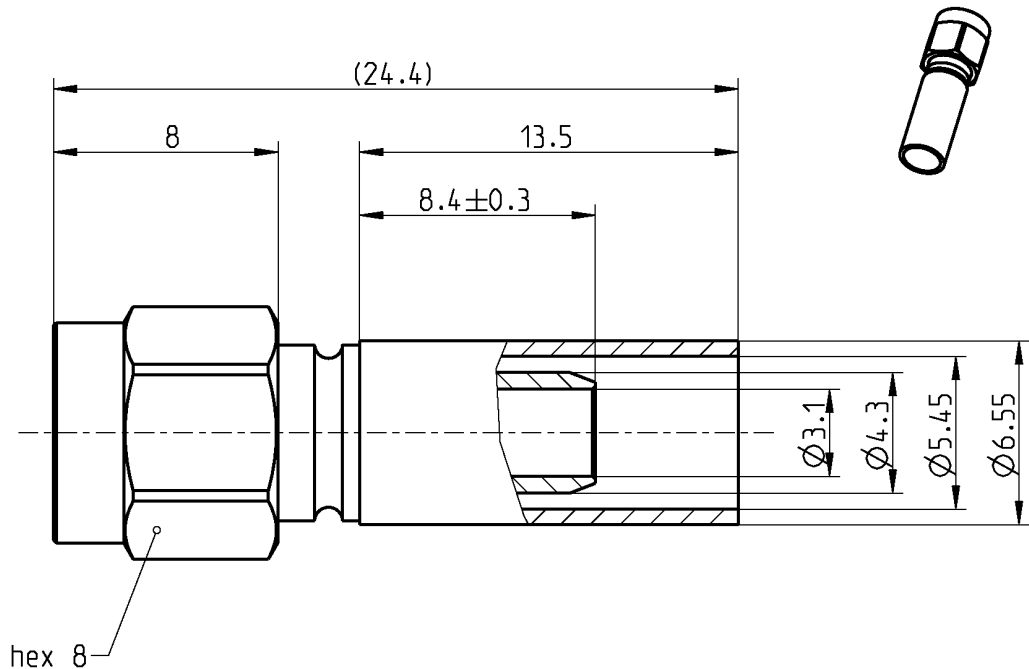

All dimensions are in mm; tolerances according to ISO 2768 m-H

Interface

According to Rosenberger 32RS000-000, series reverse SMA
 Derived from IEC 60169-15; EN 122110; MIL-STD-348A, Fig. 310
 Compliant with FCC standard (part 15; section 15.203)

Documents

Assembly instruction 32 B8

Material and plating

Connector parts

	Material	Plating
Center contact	Beryllium copper	Gold, min. 1.27 µm, over chemical nickel
Outer contact	Brass	Gold, min. 0.15 µm, over chemical nickel
Body	Brass	Gold, min. 0.15 µm, over chemical nickel
Dielectric	PTFE	
Gasket	Silicone	
Coupling nut	Brass	Gold, 0.1 µm min.
Crimping ferrule	Copper	Gold, min. 0.15 µm, over chemical nickel

Reverse SMA STRAIGHT PLUG REVERSE POLARITY

32RS147-306F3

Electrical data

Impedance	50 Ω
Frequency	DC to 12.4 GHz
VSWR	≤ 1.05 + 0.01 x f [GHz]
Insertion loss	≤ 0.05 x √f(GHz) dB
Insulation resistance	≥ 5 x10 ³ MΩ
Center contact resistance	≤ 3 mΩ
Outer contact resistance	≤ 2 mΩ
Test voltage	1000 V rms
Working voltage	480 V rms
Power handling (at 20 °C, sea level, VSWR 1.0)	≤ 200 W @ 2 GHz
RF-leakage	≥ 100 dB up to 1 GHz

- Limitations are possible due to the used cable type -

Mechanical data

Mating cycles	min. 100
Coupling nut retention	≥ 180 N
Center contact captivation: axial	≥ 27 N
Coupling test torque	max. 0.6 Nm
Recommended torque	0.5 Nm

Environmental data

Temperature range	-65°C to +165°C
Thermal shock	MIL-STD-202, Meth. 107, Cond. B
Corrosion	MIL-STD-202, Meth. 101, Cond. B
Vibration	MIL-STD-202, Meth. 204, Cond. D
Shock	MIL-STD-202, Meth. 213, Cond. I
Moisture resistance	MIL-STD-202, Meth. 106

Tooling

Crimping tool	11W150-000
Crimp insert	11W150-108

Suitable cables

RG 141 /U, RG 58 C/U

Packing

Standard	100 pcs in bag
Weight	4.2 g/pce

While the information has been carefully compiled to the best of our knowledge, nothing is intended as representation or warranty on our part and no statement herein shall be construed as recommendation to infringe existing patents. In the effort to improve our products, we reserve the right to make changes judged to be necessary.

Draft	Date	Approved	Date	Rev.	Engineering change number	Name	Date
Rong Fang	06/04/05	Chr. Entsfellner	22/04/05	a00	04-0130	Rong Fang	06/04/05
Rosenberger Hochfrequenztechnik GmbH & Co. KG P.O.Box 1260 D-84526 Tittmoning Germany www.rosenberger.de						Tel.: +49 8684 18-0 Fax: +49 8684 18-499 email: info@rosenberger.de	
						Page 2 / 2	